

# SR100 Sample Carrier

Datasheet for sample carriers which fit FC100 cells.

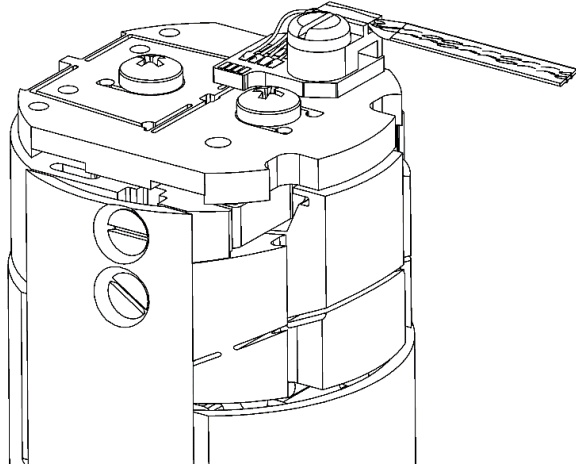

The SR100 Sample Carrier is an alternative to the standard sample plates to use with the FC100 stress cell. It supports the sample separately from the cell and is designed to allow samples to be removed from the cell and put back on, without breaking the sample. With several Sample Carriers and one cell new samples can be prepared while the cell is in use for an experiment, or samples can be tested then put aside to return to later.

The sample carrier is not suitable for all use cases however, as delicate samples may not survive handling, and the flexures used in the sample carrier cause some disturbance of the force sensor in the FC100. The SR100 is most suitable for larger, stronger samples.

## Specifications

### Parallel Stiffness of the carrier

The flexures in the sample carrier are placed in parallel with the sample. This means that as they move, the force needed to deflect them will be recorded by the force sensor and added to the force needed to strain the sample. The stiffness of these flexures is around  $0.04 \text{ N}/\mu\text{m}$  but does vary between individual carriers. The sample carrier would produce a force of around 2 N if the FC100 were exercised to its full room temperature travel range. The best way of addressing this effect is to ensure the sample is much stiffer than the carrier.

### Series Stiffness

The hinges necessary to take up any misalignment when the carrier is mounted back on the cell also have some compliance when the cell is applying force to the sample. The spring constant of the sample carrier is approximately  $4 \text{ N}/\mu\text{m}$  and lies in series with the  $5 \text{ N}/\mu\text{m}$  spring constant of the cell itself. This has the effect of reducing the apparent stiffness of the cell to  $2.2 \text{ N}/\mu\text{m}$ . This means that although the full displacement range of the cell remains available, the zero-displacement force reduces to approximately 50 N at 4 K. The FC100 manual has further discussion of cell and sample stiffness.

## Using the sample carrier

There are two possible approaches to using the sample carrier. Firstly, the sample may be mounted on the carrier when the carrier is on the cell. Alternatively, the sample may be mounted on a carrier that has been removed from the cell.

Mounting the sample when the carrier is on the cell is likely to give the best results. Once the sample mounting epoxy has cured it

should be possible to remove and reattach the carrier. The clamp bar may not be needed.

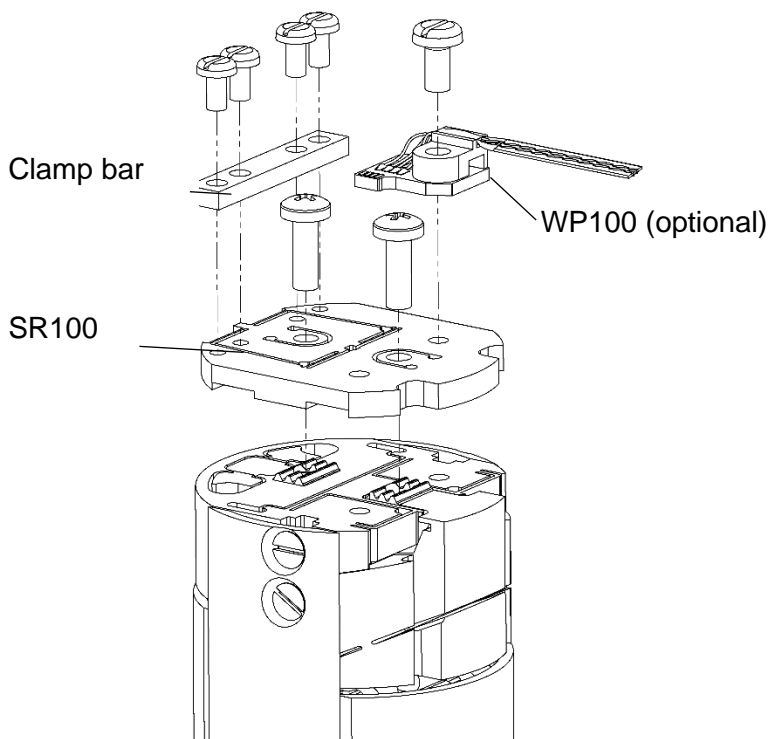

Mounting the sample with the carrier off the cell is particularly useful when using epoxies that need to be cured at higher temperature than the cell can withstand. In this case the sample carrier must be locked to the correct length using the supplied clamp. If this is not done, the carrier will adjust to fit the tooth spacing on the FC100 as it is mounted, and this is likely to break the sample.

To lock the carrier to the correct length, mount it on the cell, apply the clamping bar, then remove the carrier from the cell. Once a

sample is mounted and the epoxy has cured the clamping bar may no longer be needed, but we recommend putting the carrier back on the cell before removing it to avoid breaking the sample when loosening the screws.

The Sample Carrier should be attached to the cell with M2 x 5 or M2 x 6 screws, preferably titanium. Suitable screws are supplied with every FC100 cell, and Razorbill Instruments can supply small quantities on request. To minimise the difference in position between each mounting, keep the mating faces clean and free of debris.

## Sample mounting arrangement

The FC100 standard sample plates can be moved in and out to adjust the free length of the sample. As the carrier is a single piece of titanium, the gap over which the sample is mounted cannot be easily adjusted. Please contact Razorbill Instruments if your samples cannot conform to these size requirements and we may be able to customise the SR100 prior to shipping.

As there is a hinge between the sample mounting area and the bolt, it is not practical to use a sample mounting plates held in place by the bolt, as is the case when the cell is used without a carrier. To maximise strain homogeneity a top plate should still be used, and a spacer is still useful in setting the epoxy thickness around the sample. Suitable spacers and top plates are included with the Sample Carrier.

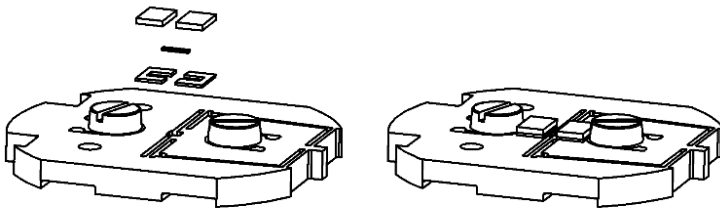

When gluing the specimen directly to the carrier, the sample length cannot be set by sliding the sample plates forward and back because the lower surface will be the carrier itself. The gap in the centre of the carrier is 1.2 mm, but this can be extended by removing material from the carrier using e.g. wire EDM or an abrasive slurry saw. To prevent damage to the flexures, the carrier must be immobilised before any machining step using the blocking bar.

The carrier will fit either way around on the cell, but to enable cables to be threaded through the “B” exits (see the FC100 datasheet) it should be mounted with the two cut-outs over the cable exits.

## Using a WP101 wiring platform with a sample carrier

The WP101 wiring platform offers 4 or 8 electrical contacts close to the sample. Contacts are supplied through twisted pair wiring and fitted with a copper heat sink. For more information see the WP101 datasheet.

The sample carrier has two tapped holes in it; these are positioned so that WP101 wiring platforms can be mounted on the carrier. These holes line up over the holes in the cell where the platforms can be attached if the sample carrier isn't used. Use M2 x 5 screws, which will secure the wiring platform without protruding from the bottom of the sample carrier.



*Do not put a screw right through the threaded hole in the sample carrier and into the cell below, as this may damage the carrier.*

## Accessories and replacement parts

	<b>Part Number</b>	<b>Description</b>
<b>Spacers and sample mounting plates</b>	SP150	Replacement rectangular upper sample plates and C shaped spacers
<b>Wiring Platform</b>	WP100	Provides 4 or 8 electrical contacts close to the sample, with incoming wiring passing through a copper heat sink. See WP100 datasheet for options
<b>Clamp bar screws</b>	N/A	M1.6 x 3 Brass
<b>Wiring platform screw</b>	N/A	M2 x 5 Brass
<b>Carrier-to-cell screws</b>	N/A	M2 x 5 Titanium